



1074 Kenran Industrial Dr.  
St. Louis, MO 63137  
Phone: 1-800-381-9968

# HUMCO RIGGING/RATCHETS

## Wire Rope Attachments

### Wire Rope Clips

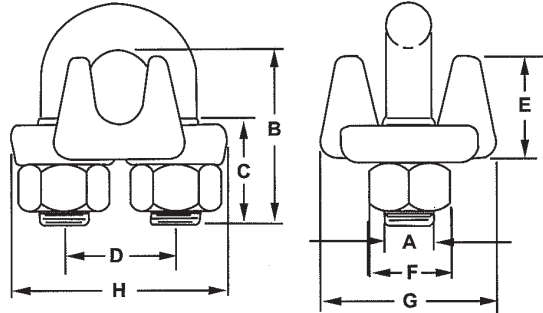

Size	Product Code	Dimensions								Min No Clips	Torque	Rope Turnbuckle	Weight
		A	B	C	D	E	F	G	H				
<b>Imperial</b>													
in.		in.	in.	in.	in.	in.	in.	in.	in.		ft./lb.	in.	lb.
1/8*	M244	1/8-24UNC	23/32	7/16	15/32	13/32	3/8	13/16	15/16	2	4-1/2	3-1/4	5
3/16*	M245	1/4-20UNC	31/32	9/16	19/32	1/2	1/2	15/16	1-5/32	2	7-1/2	3-3/4	9
1/4	M246	5/16-18UNC	1-1/32	1/2	3/4	31/32	9/16	1-3/16	1-7/16	2	15	4-3/4	18
5/16	M247	3/8-16UNC	1-3/8	3/4	7/8	23/32	11/16	1-5/16	1-11/16	2	30	5-1/4	30
3/8	M248	7/16-14UNC	1-1/2	3/4	1	29/32	3/4	1-5/8	1-15/16	2	45	6-1/2	42
7/16	M249	1/2-13UNC	1-7/8	1	1-3/16	1-1/16	7/8	1-25/32	2-5/16	2	65	7	70
1/2	M250	1/2-13UNC	1-7/8	1	1-3/16	1-1/8	7/8	1-29/32	2-5/16	3	65	11-1/2	75
9/16	M296	9/16-12UNC	2-3/8	1-1/4	1-5/16	1-1/4	15/16	1-31/32	2-1/2	3	95	12	100
5/8	M251	9/16-12UNC	2-3/8	1-1/4	1-5/16	1-11/32	15/16	2	2-1/2	3	95	12	100
3/4	M252	5/8-11UNC	2-3/4	1-7/16	1-1/2	1-7/16	1-1/16	2-11/32	2-13/16	4	130	18	150
7/8	M253	3/4-10UNC	3-1/8	1-5/8	1-3/4	1-19/32	1-1/4	2-7/16	3-5/32	4	225	20	240
1	M254	3/4-10UNC	3-1/2	1-13/16	1-7/8	1-25/32	1-1/4	2-5/8	3-5/32	5	225	26	250
1-1/8	M255	3/4-10UNC	3-7/8	2	2	1-25/32	1-1/4	2-13/16	3-19/32	6	225	34	310
1-1/4	M256	7/8-9UNC	4-1/4	2-1/8	2-5/16	2-3/16	1-7/16	3-1/8	4-1/8	7	360	37	460
1-3/8	M257	7/8-9UNC	4-5/8	2-5/16	2-3/8	2-1/4	1-7/16	3-1/8	4-1/4	7	360	44	520
1-1/2	M258	7/8-9UNC	4-15/16	2-3/8	2-19/32	2-1/2	1-7/16	3-1/8	4-7/16	8	360	48	590

#### Proper use of Wire Rope Clips

1. Refer to the chart above in following these instructions. Turn back specified amount of rope from thimble or loop. Apply first clip one base width from dead end of rope. Apply U-bolt over dead end of wire rope - live end rests in saddle. Tighten nuts evenly, alternate from one nut to the other until reaching the recommended torque.
2. When two clips are required, apply the second clip as near the thimble or loop as possible. Tighten nuts evenly, alternating until reaching the recommended torque. When more than two clips are required, apply the second clip as near the loop or thimble as possible, turn nuts on second clip firmly, but do not tighten. Proceed to Step 3.
3. When three or more clips are required, space additional clips equally between the first two - take up rope slack - tighten nuts on each U-bolt evenly, alternating from one nut to the other until reaching the recommended torque.
4. Apply an initial load equal to loads expected in use. Inspect for proper orientation and spacing of clips and retighten the nuts to recommended torque.

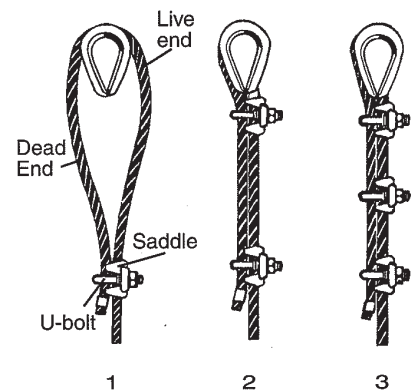

**▲ WARNING ▲**

Improper installation and use of wire rope clips can result in injury.

**To avoid injury:**  
Install and use only as instructed herein.



1074 Kenran Industrial Dr.  
 St. Louis, MO 63137  
 Phone: 1-800-381-9968

# HUMCO RIGGING/RATCHETS

## Wire Rope Attachments

### Piggyback Wedge Socket Clips

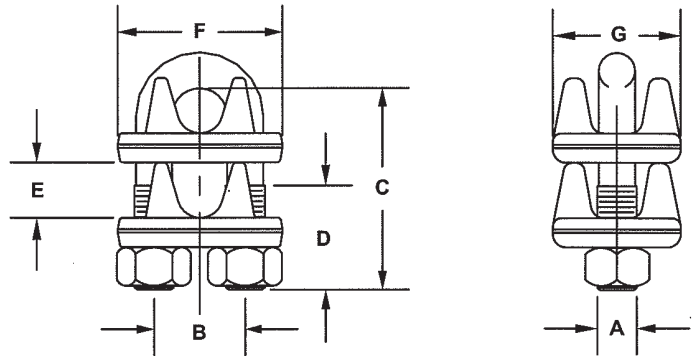

Size	Product Code	Saddle	U-Bolt	Dimensions							Heavy Hex Nut galv.	Torque	Min. Tail	Weight
				A	B	C	D	E	F	G				
<b>Imperial</b>														
in.				in.	in.	in.	in.	in.	in.	in.		ft./lb.	in.	lb.
3/8	M248D	1X248	2X248L	7/16-14UNC	1.00	2.38	1.00	0.53	1.94	1.62	602224	45	6	0.8
7/16	M249D	1X249	2X250L	1/2-13UNC	1.19	2.62	1.00	0.66	2.31	1.78	602225	65	6	1.3
1/2	M250D	1X250	2X250L	1/2-13UNC	1.19	2.62	1.00	0.72	2.31	1.91	602225	65	6	1.4
9/16	M296D	1X296	2X251L	9/16-12UNC	1.31	3.19	1.25	0.77	2.50	1.97	602226	95	6	1.7
5/8	M251D	1X251	2X251L	9/16-12UNC	1.31	3.19	1.25	0.81	2.50	2.00	602226	95	6	1.7
3/4	M252D	1X252	2X252L	5/8-11UNC	1.50	3.50	1.50	0.91	2.81	2.34	602227	130	6	2.5
7/8	M253D	1X253	2X253L	3/4-10UNC	1.75	3.88	2.00	1.07	3.16	2.44	602228	225	6	3.6
1	M254D	1X254	2X254L	3/4-10UNC	1.88	4.25	2.00	1.22	3.47	2.62	602228	225	6	3.9
1-1/8	M255D	1X255	2X255L	3/4-10UNC	2.00	4.50	2.00	1.31	2.59	2.81	602228	225	6-3/4	4.9
1-1/4	M256D	1X256	2X256L	7/8-9UNC	2.31	5.25	2.38	1.50	4.22	3.18	602246	360	7-1/2	6.5
1-3/8	M257D	1X257	2X257L	7/8-9UNC	2.38	5.62	2.38	1.56	4.25	3.08	602246	360	8-1/4	7.1
1-1/2	M258D	1X258	2X258L	7/8-9UNC	2.59	6.00	2.38	1.75	4.47	3.41	602246	360	9	8.2

#### Proper use of PiggyBack Wedge Socket Clips

1. Dead end wire rope tail length should be at least 6 rope diameters, but not less than 6 inches beyond the wedge socket. Figure 1.
2. Apply U-bolt and first saddle on dead end rope and the second saddle on live end rope. Install nuts. Figure 1 & 2
3. Position the dual saddle clip so that 3 to 4 inches of dead end rope remain beyond the clip. Figures 1 & 2.
4. Tighten nuts evenly. Alternate tightening each nut until reaching the required torque specified. Figure 2.
5. Check that clip does not pinch or clamp the live wire rope. Apply an initial test load equal to the loads expected in regular use. Be certain rope is secured properly in the wedge socket prior to any use.
6. Inspect for proper rope alignment with wedge socket and retighten the nuts to the specified torque.

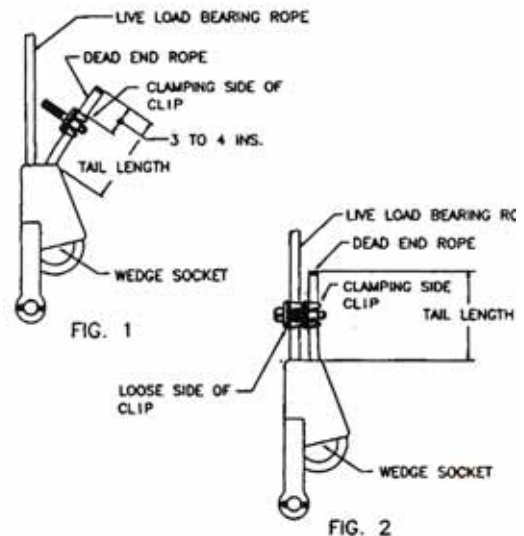



1074 Kenran Industrial Dr.  
St. Louis, MO 63137  
Phone: 1-800-381-9968

# HUMCO RIGGING/RATCHETS

## Wire Rope Attachments

### Thimbles

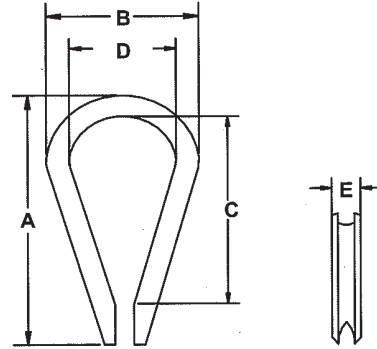

Rope Diameter	Product Code	Standard Pack	Dimensions					Weight	
			A	B	C	D	E		
<b>Imperial</b>									
in.			in.	in.	in.	in.	in.	in.	lb.
<b>Malleable Wire Rope Thimbles (Zinc Plated)</b>									
1/8	86095	100	1.94	1.06	1.31	0.69	0.25	0.035	
3/16	86195	100	1.94	1.06	1.31	0.69	0.31	0.035	
1/4	86295	100	1.94	1.06	1.31	0.69	0.38	0.035	
5/16	86395	100	2.13	1.25	1.5	0.81	0.44	0.040	
3/8	86495	50	2.38	1.47	1.63	0.94	0.53	0.070	
1/2	86695	50	2.75	1.75	1.88	1.13	0.69	0.125	
5/8	86895	25	3.50	2.38	2.25	1.38	0.91	0.345	
<b>Heavy Duty Wire Rope Thimbles (Hot Galvanized)</b>									
1/4	87296	25	2.19	1.50	1.63	0.88	0.41	0.075	
5/16	87396	25	2.50	1.81	1.88	1.06	0.5	0.140	
3/8	87496	25	2.88	2.13	2.13	1.13	0.66	0.250	
1/2	87696	25	3.63	2.56	2.75	1.50	0.84	0.510	
5/8	87896	10	4.25	3.00	3.25	1.75	1.00	0.750	
3/4	87906	10	5.00	3.50	3.75	2.00	1.25	1.470	
7/8	87916	10	5.50	4.00	4.25	2.25	1.38	1.850	